



**ELECTRIC COMBI WALL BOILER
FOR HEATING AND SANITARY HOT WATER PRODUCTION
INSTANTANEOUS WITH ACCUMULATION TANK**

Combi. Elektra .. BP-L HE series



USE AND MAINTENANCE MANUAL



EQUIPMENT COMPLIANT CE DIRECTIVE 2006/42 - IEC 60335-2-21:2012 with IEC 60335-60335-2-21:2003+A1:2005+A2:2008 - EN 60335-1:2012 - EN 62233:2008.

ELECTRIC WALL BOILER



Series **ELEKTRA**. ... **BP-L HE**

Presentation

Thank you for choosing an electric wall boiler FIAMMA, built with the most modern technologies, safe and tough materials, so as to ensure maximum efficiency of use, total quality of the device and extreme safety for the user.

The series Elektra .. is built according to European standards dir. machines 2006/42 - IEC 60335-2-21:2012 IEC 60335-1:2010 and EN 60335-2-21:2003 + A1 : 2005 + A2 : 2008 - EN 60335-1:2012 - EN 62233:2008 .

The obtained results can be summarized in the following key points:

- Noiseless functioning, thanks to maximum insulation of the device by means of innovative special materials that ensures minimum heat loss.*
- High degree of reliability, thanks to a careful choice of materials and to sever tests carried out during production for each unit built.*
- High performance with maximum efficiency, thanks to a modulation of electrical power to the heating elements, according to the actual need of energy by the system or the need of sanitary water. The system D.E.S. manages the device with temperature probes positioned in each sensitive point of the boiler, so as to manage both comfort and economy functioning, in order to reduce power consumption when the device is not used at the maximum capacity or demand.*
- The appliance is fully adjustable both in water temperature of the heating system (with the possibility to choice of system at high and low temperature for underfloor systems) and in the domestic hot water temperature.*
- The assembly of the components has been realized in order to allow an easy access to them, all from the front of the unit, for ordinary and extraordinary maintenance.*

We recommend you to follow our instructions, and we suggest to contact the area authorized service FIAMMA in order to prepare a planned maintenance contract which can ensure suitable operation at maximum efficiency and safety, so that your machine use can go a long way.

In renewing our thanks, our technical department and our sales network, are at your disposal for any further information

FIAMMA GIRO s.r.l.
Company group



*The company **FIAMMA GIRO s.r.l.** declines all responsibility for possible inaccuracies contained in this pamphlet, if due to printing errors or inadvertent errors. However, reserves the right to make changes to its products that it deems useful or necessary, without affecting the essential characteristics of the products manufactured and marketed.*



Dimensions

The series **Elektra... BP-L HE** has four power levels, but the same overall dimensions:

Elektra.6 BP-L HE 6 kW maximum electrical output

Elektra.12 BP-L HE 12 kW maximum electrical output

Elektra.18 BP-L HE 18 kW maximum electrical output

Elektra.24 BP-L HE 24 kW maximum electrical output

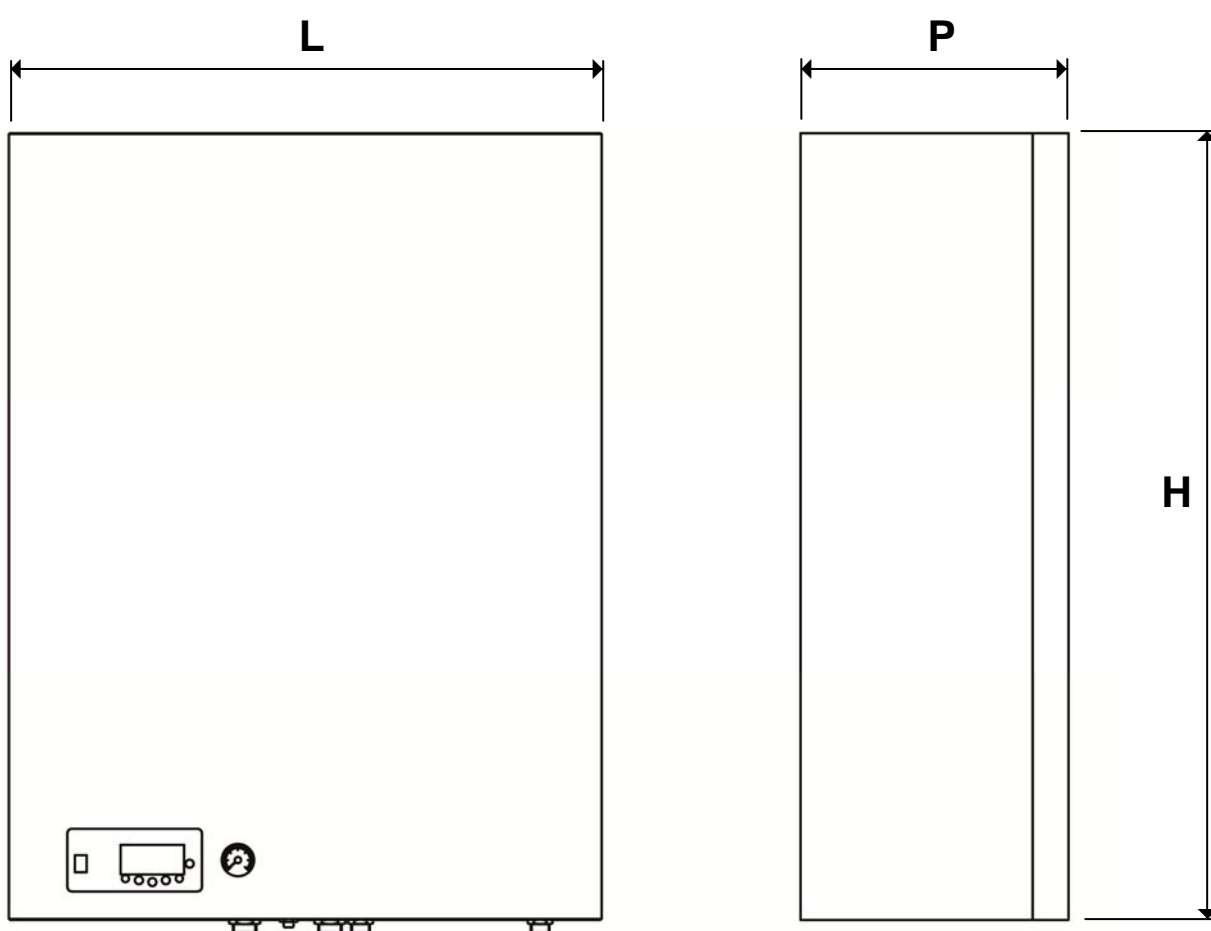

Appliance dimension

L (Width) : 660 mm
H (Height) : 875 mm
P (Depth) : 300 mm
Weight : 61 kg

Packaging dimension

Width: 710 mm
Height : 940 mm
Depth : 390 mm
Weight : 64,5 kg

Hydraulic connections – Dimensional of connection arrangement.



Hydraulic connections

M	Heating delivery :	3/4"	M
R	Heating return :	3/4"	M
AF	Cold sanitary water inlet :	1/2"	M
AC	Hot sanitary water output:	1/2"	M
VSR	Heating safety valve (3 bar) :	1/2"	F
VSS	Sanitary safety valve (6,5 bar) :	1/2"	F
RC	Manual Filling tap (restoring water pressure)		

Bottom view (under the boiler)

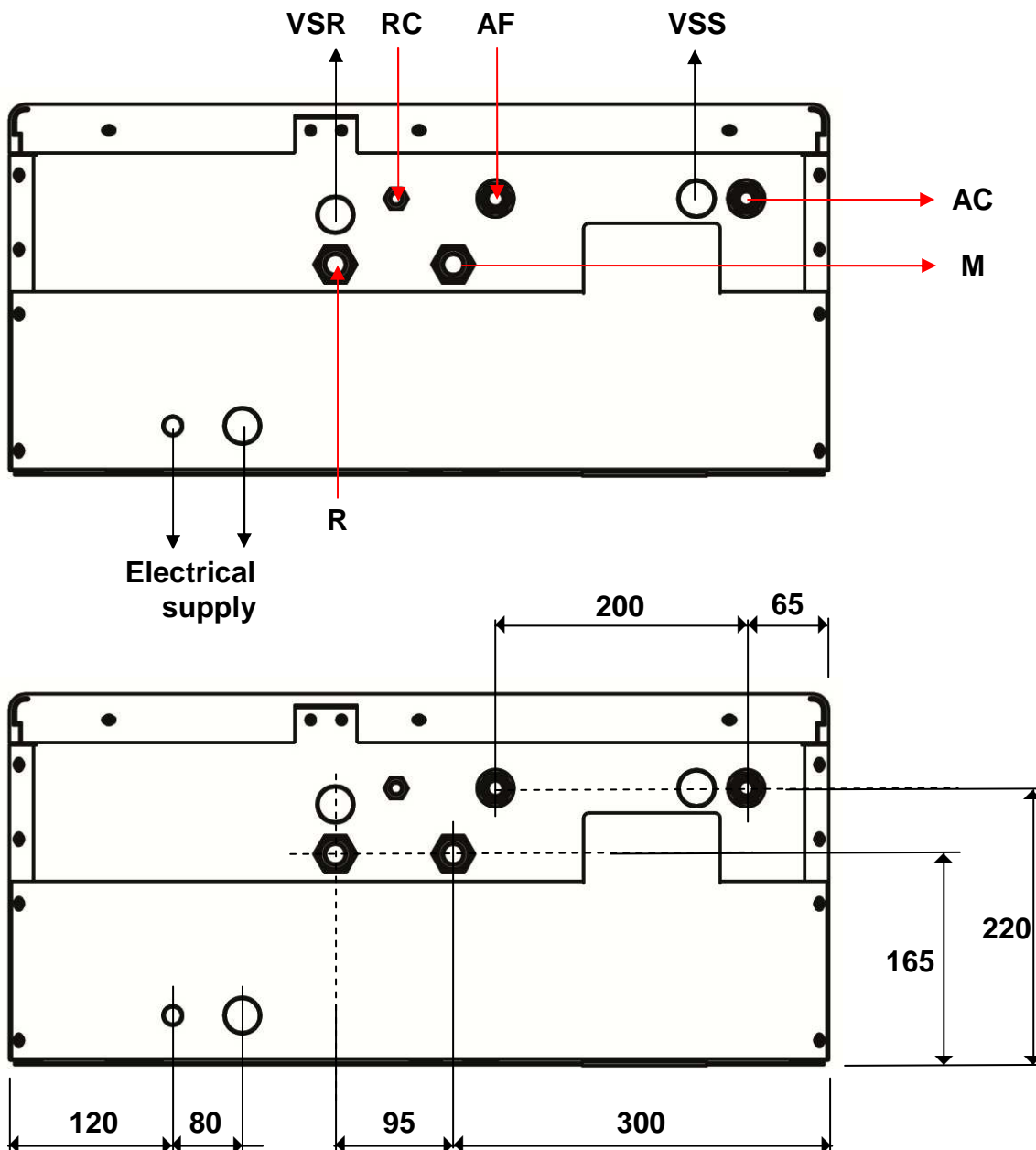

Main technical features Elektra 6.. - Elektra 12..



Elektra.6 BP-L HE 6 kW maximum electrical output

Single-phase electrical supply 230 V - 50 Hz.

Weight : 60 kg.

Capacity of tank 37 lt. Glass-lined steel with inspection flange and magnesium anode.

Electrical / heat power available at heating: 6 kW obtained by n°2 resistance group (n°2 3x1 kW).

Electrical power at hot water tank resistance: 2 kW (2.000 W).

Maximum head available at the pump 5 m H₂O

Expansion vessel capacity of 8 lt.

Safety valve of heating circuit: 3 bar.

Safety valve of sanitary circuit: 6,5 bar.

Maximum heating operating pressure: 2.5 bar.

Maximum sanitary operating pressure: 5.5 bar.

Minimum operating pressure in the heating circuit: 0.6 bar.

Minimum operating pressure in the sanitary, comfort system: 0.25 bar.

Minimum operating pressure in the sanitary, economy system: 0.05 bar.

Maximum limit of thermal safety heating circuit - boiler body: 100 °C.

Elektra.12 BP-L HE 12 kW maximum electrical output

Single-phase electrical supply 230 V - 50 Hz.

Weight : 61 kg.

Capacity of tank 37 lt. Glass-lined steel with inspection flange and magnesium anode.

Electrical / heat power available at heating: 12 kW obtained by n°2 resistance groups (n°2 3x2 kW).

Electrical power at hot water tank resistance: 2 kW (2.000 W).

Maximum head available to the pump 5 m H₂O

Expansion vessel capacity of 10 lt.

Safety valve of heating circuit: 3 bar.

Safety valve of sanitary circuit: 6,5 bar.

Maximum heating operating pressure: 2.5 bar.

Maximum sanitary operating pressure: 5.5 bar.

Minimum operating pressure in the heating circuit: 0.6 bar.

Minimum operating pressure in the sanitary, comfort system: 0.25 bar.

Minimum operating pressure in the sanitary, economy system: 0.05 bar.

Maximum limit of thermal safety heating circuit - boiler body: 100 °C.

Main technical features of Elektra 18.. – Elektra 24..



Elektra.18 BP-L HE 18 kW maximum electrical output

Single-phase electrical supply 230 V - 50 Hz.

Weight : 62 kg.

Capacity of tank 37 lt. Glass-lined steel with inspection flange and magnesium anode.

Electrical / heat power available at heating: 18 kW obtained by n°3 resistance groups (n°3 3x2 kW).

Electrical power at hot water tank resistance: 2 kW (2.000 W).

Maximum head available at the pump 5 m H₂O

Expansion vessel capacity of 10 lt.

Safety valve of heating circuit: 3 bar.

Circuit safety valve of sanitary circuit: 6,5 bar.

Maximum heating operating pressure: 2.5 bar.

Maximum sanitary operating pressure: 5.5 bar.

Minimum operating pressure in the heating circuit: 0.6 bar.

Minimum operating pressure in the sanitary, comfort system: 0.25 bar.

Minimum operating pressure in the sanitary, economy system: 0.05 bar.

Maximum limit of thermal safety heating circuit - boiler body: 100 °C.

Elektra.24 BP-L HE 24 kW maximum electrical output

Single-phase electrical supply 230 V - 50 Hz.

Weight : 63 kg.

Capacity of tank 37 lt. Glass-lined steel with inspection flange and magnesium anode.

Electrical / heat power available at heating: 24 kW obtained by n°4 resistance groups (n°4 3x2 kW).

Electrical power at hot water tank resistance: 2 kW (2.000 W).

Maximum head available to the pump 6 m H₂O.

Expansion vessel capacity of 10 lt.

Safety valve of heating circuit: 3 bar.

Safety valve of sanitary circuit: 6,5 bar.

Maximum heating operating pressure: 2.5 bar.

Maximum sanitary operating pressure: 5.5 bar.

Minimum operating pressure in the heating circuit: 0.6 bar.

Minimum operating pressure in the sanitary, comfort system: 0.25 bar.

Minimum operating pressure in the sanitary, economy system: 0.05 bar.

Maximum limit of thermal safety heating circuit - boiler body: 100 °C.

Switching-on the boiler



CONTROL PANEL

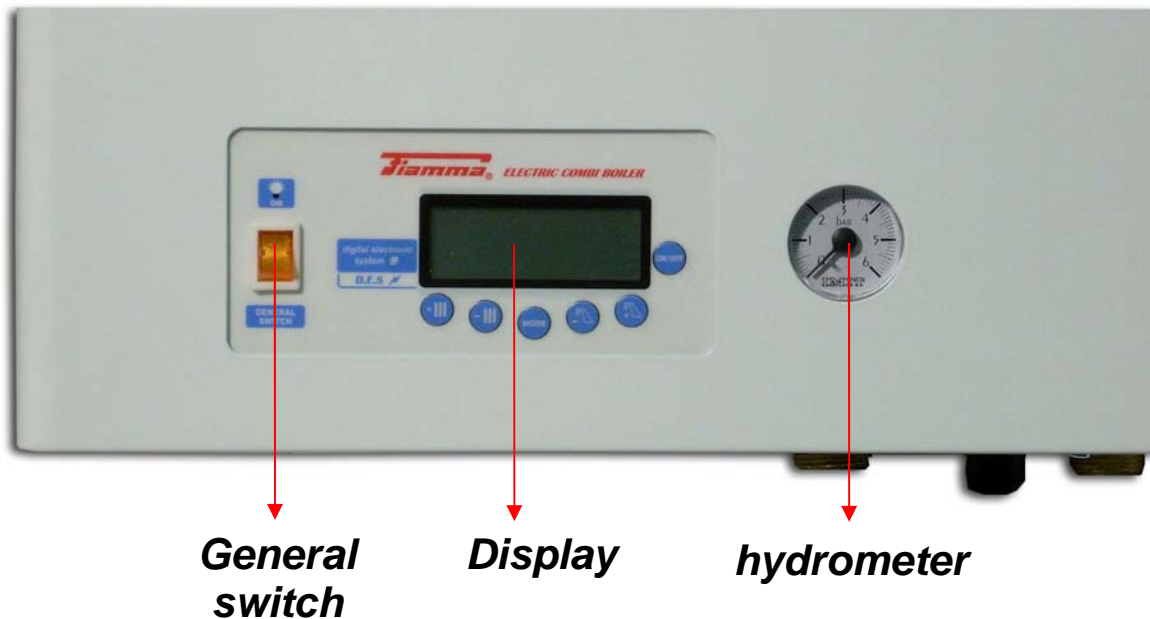

The control panel is composed of : display, function selection keys, general switch and the hydrometer it is placed in the lower left corner in front of the unit (see image above).

Using analogical hydrometer.

The analogical hydrometer control panel has a dial with unit of measure in a bar, from 0 to 6 bar. The water pressure in the heating system is indicated by the index of the black arrow.

The optimum pressure for the system is between 1 and 1.5 bar.

More than 1.5 bar you can have a maximum pressure of 2 bar (maximum expansion of the system during the rise in temperature). More than 2 bar pressure the system is not in the range of operation, and mechanical safety valve (preset to 3 bar) can start to lose water.

The minimum operating pressure is 0.8 bar (+/- 0.2 bar). The differential positive or negative tolerance is due to the operation of the water pressure switch with fixed setting.

KEYBOARD PANEL (Control panel)

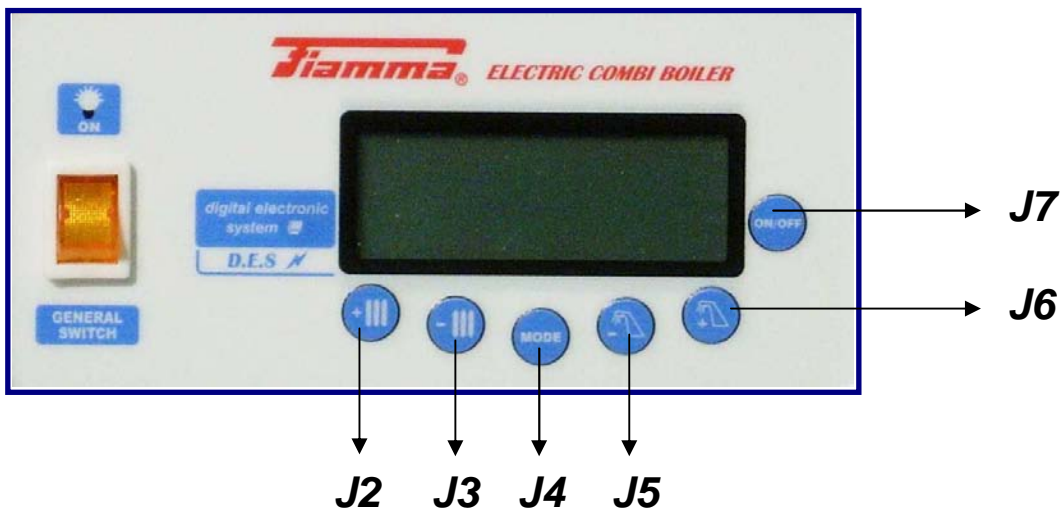

MEANING OF THE KEYS IN USER MODE

KEY	FUNCTION
J5	Display / Tank setpoint decrease (only if JP8 = 0)
J6	Display / Tank setpoint increase (only if JP8 = 0)
J7	ON - OFF Switching Display temperature output / Display setpoint output Unlock error of safety thermostat
J4	Summer – Winter switching
J2	Display / Increase of heating setpoint (or room temperature)
J3	Display / Decrease of heating setpoint (or room temperature)
J5 + J6	Enabling function Eco/Comfort (only if JP8 = 0)
J4 + J7	Start function degassing

TURNING ON THE BOILER

The boiler is switched-on by means of the light General switch located on the left of the display in the instrument panel of the boiler. Pressing the switch upward to the ON position, it will light in the presence of single-phase supply (230V-50 Hz). Then, it shall be pressed the ON-OFF (J7) on the keypad to switch the power from stand-by to the operating position; the display will light up of blue and will appear various symbols signaling function /faults etc. At this point it shall be chosen the mode of operation, summer or winter operation.

CHOICE OF THE OPERATION MODE (winter/summer)



Pressing the key MODE (J4), it will be chosen the mode of operation, wintry or summery.

Pressing repeatedly each time for at least 5 seconds, you switch from WINTER to SUMMER or from SUMMER to WINTER then.

When the device will be in WINTER mode, on the display will appear the symbol ❄️ (snow).

When the device will be in SUMMER mode, on the display will appear the symbol ☀️ (sun).

TEMPERATURE VARIATION OF THE HEATING CIRCUIT

When the apparatus has been set with the snow symbol (❄️) for the wintry functioning, you can change the maximum temperature of heating circuit pressing one of the two keys with the radiator symbol located on the left of the display (J2 and J3 keys).

The key with the symbol III+ (J2), increases the temperature, and the key with the symbol III- (J3), decreases the temperature.

TEMPERATURE VARIATION OF HOT SANITARY WATER

The temperature of hot sanitary water can be varied independently from the mode of functioning, both wintry and summery.

The two keys with the Tap symbol on the left of the control panel, are used to set the maximum temperature of the hot sanitary water circuit.

The key with symbol 🚰+ (J6) increases the temperature, and the one with the symbol 🚰- (J5) decreases the temperature.

ON-OFF KEY

Display Simbols

The ON/OFF key (J7), in addition to put the boiler in stand-by mode, allows to reset (unlock) the apparatus in case of high temperature lock.



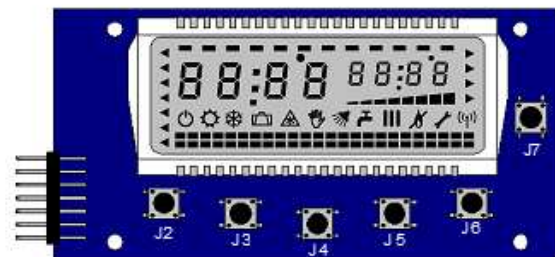







If the lock would be caused by lack of water





pressure alarm, the recovery will be automatic after that the hydric pressure will be restored at the minimum operating level (0,8 bar) by means of the opening and the closure of the charging tap placed under the boiler (black handle).

The display has several symbols, signaling in addition to operation modes, also the various alarm or system displays:

SYMBOL	MEANING
	<i>Malfunction</i>
	<i>Request of burner switch-on</i>
	<i>Heating request</i>
	<i>Tank enabled</i>
	<i>Function sanitary Comfort activated</i>
	<i>Parameter menu activated</i>
	<i>Anti-freeze request activated</i>
	<i>Winter mode</i>
	<i>Summer mode</i>
	<i>OFF mode</i>
Level of modulation	<i>Indicates the instantaneous power of the boiler from 0 to 100%</i>

INSTALLATION

TECHNICAL NOTE FOR INSTALLER AND TECHNICAL MAINTENANCE



HYDRAULIC SCHEME

(Elektra 12 BP-L 015 HE version)

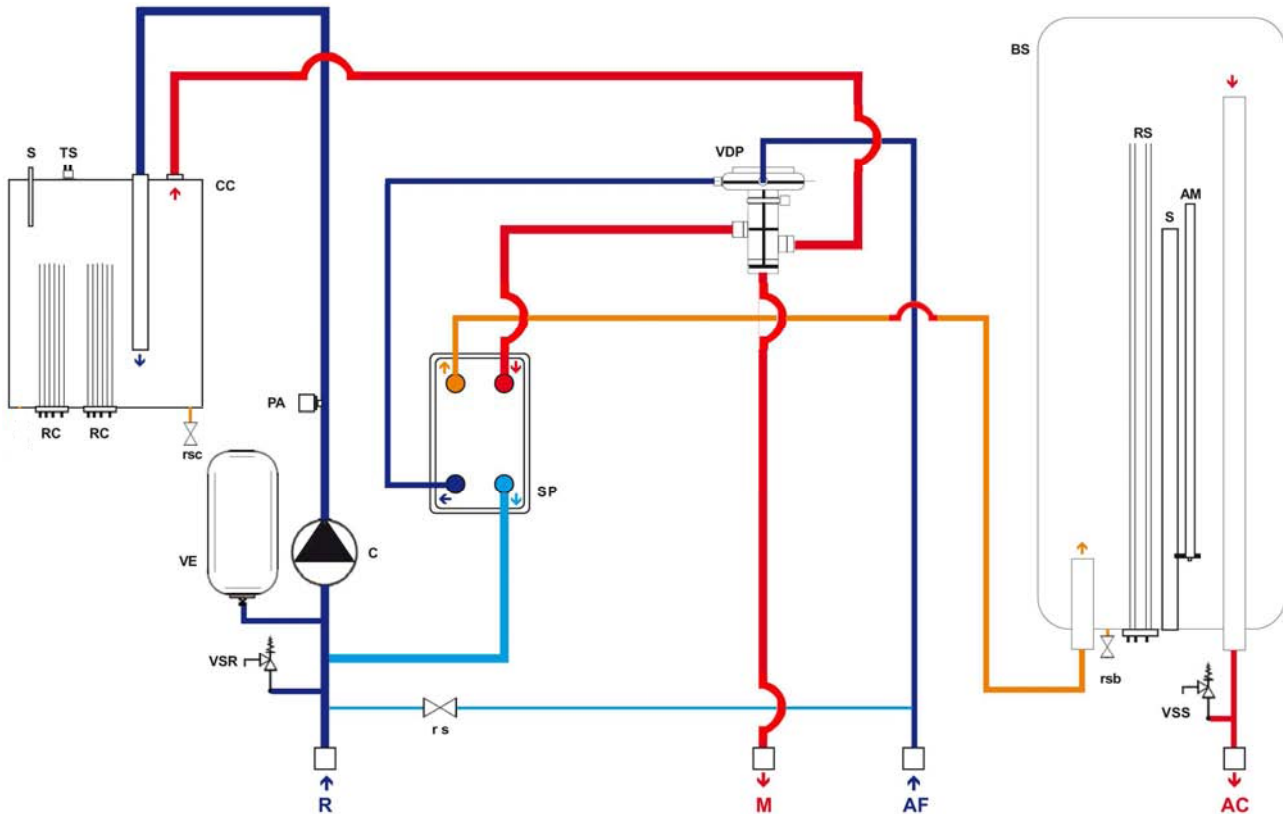

Legend

- **TS** Safety thermostat.
- **VSS** Safety valve for sanitary circuit 1/2"x6,5 bar.
- **SP** Brazed heat exchangers.
- **S** Thermowell for immersion sensor.
- **R** Hydraulic connection in-let heating circuit.
- **AC** Hydraulic connection out-let sanitary hot-water.
- **M** Hydraulic connection out-let heating circuit.
- **RS** Sanitary Resistance of 2 kW.
- **VE** Expansion vessel heating circuit.
- **VSR** Safety valve heating circuit 1/2"x3 bar
- **AF** Hydraulic connection in-let sanitary cold-water.
- **rs** Filling tap.
- **PA** Water pressure switch.
- **CC** Boiler body.
- **VDP** Pressostatic Diverter valve.
- **RC** Boiler resistance of 6 kW.
- **rsc** Drain valve of boiler body.
- **BS** Hot water storage tank of 37 lt.
- **AM** Magnesium anode.
- **rsb** Drain valve of tank.

For the other models, the only changes refer to the number of electric resistances; the 6 kW version has two 3 kW resistance (detail RC), the 12 kW version has two 6 kW resistances, the 18 kW version has three 6 kW resistances and the 24 kW version has four 6 kW resistances.

CONNECTING SCHEME

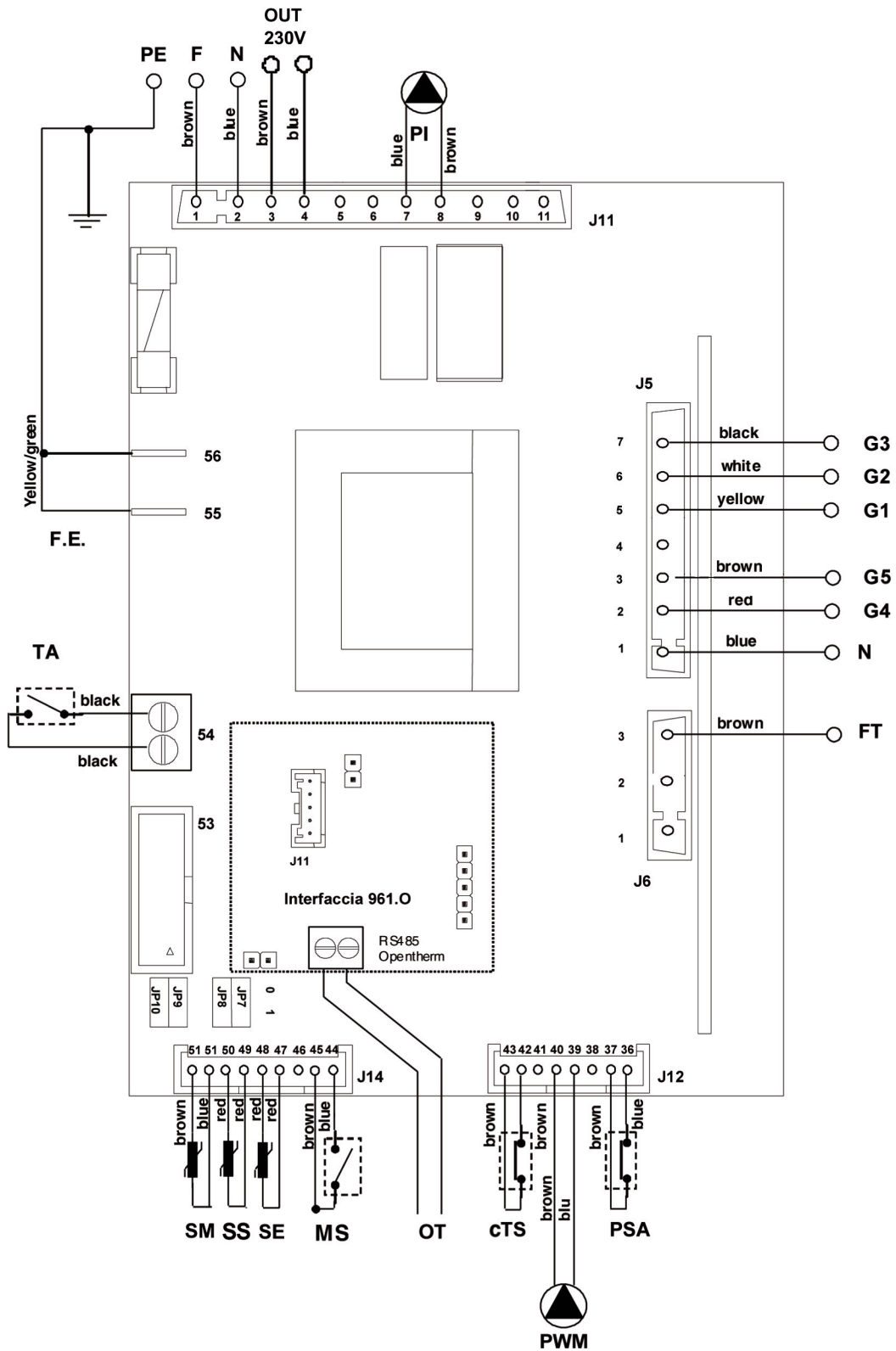



MAIN ELECTRIC SCHEME

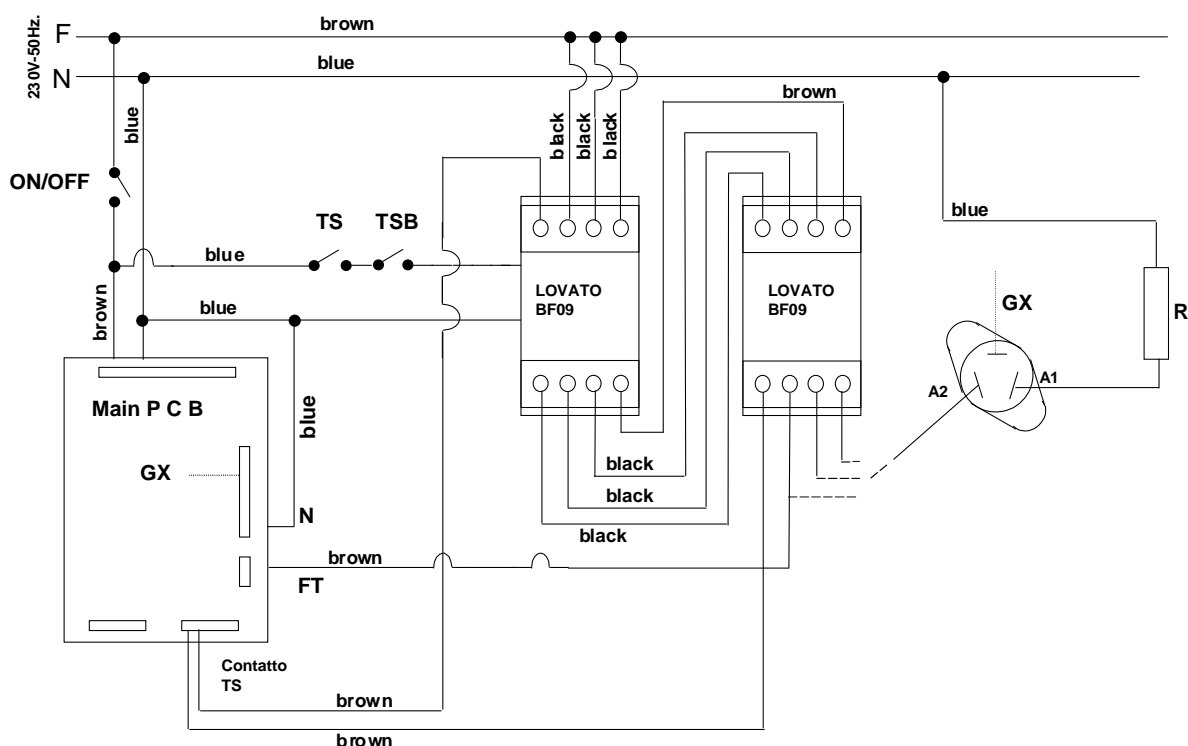

Legend electric scheme

Single phase	F
Neutral	N
Selected Phase from Contactor	FT
Electric Pump	PI
Control of contact TS on Contactor of power (C-NO)	cTS
Sanitary Microswitch (control Comfort function)	MS
Control gate triac n°1 (4KW power)	G1
Control gate triac n°2 (2KW power)	G2
Control gate triac n°3 (4KW power)	G3
Control gate triac n°4 (2KW power)	G4
Control gate triac n°5 (2KW sanitary tank)	G5
Delivery heating probe (ntc sensor)	SM
External probe (sensor)	SE
Water pressure switch	PSA
Safety thermostat - Safety thermostat tank	TS - TSB
Room thermostat (terminal provided)	TA
Ground point of this affordable security application	PE
Sanitary tank probe (sensor)	SS
Functional heart derived from ground point of security	F.E.
Connection with remote control OpenTherm (optional)	OT
General switch	ON/OFF

TRIAC – Connection scheme

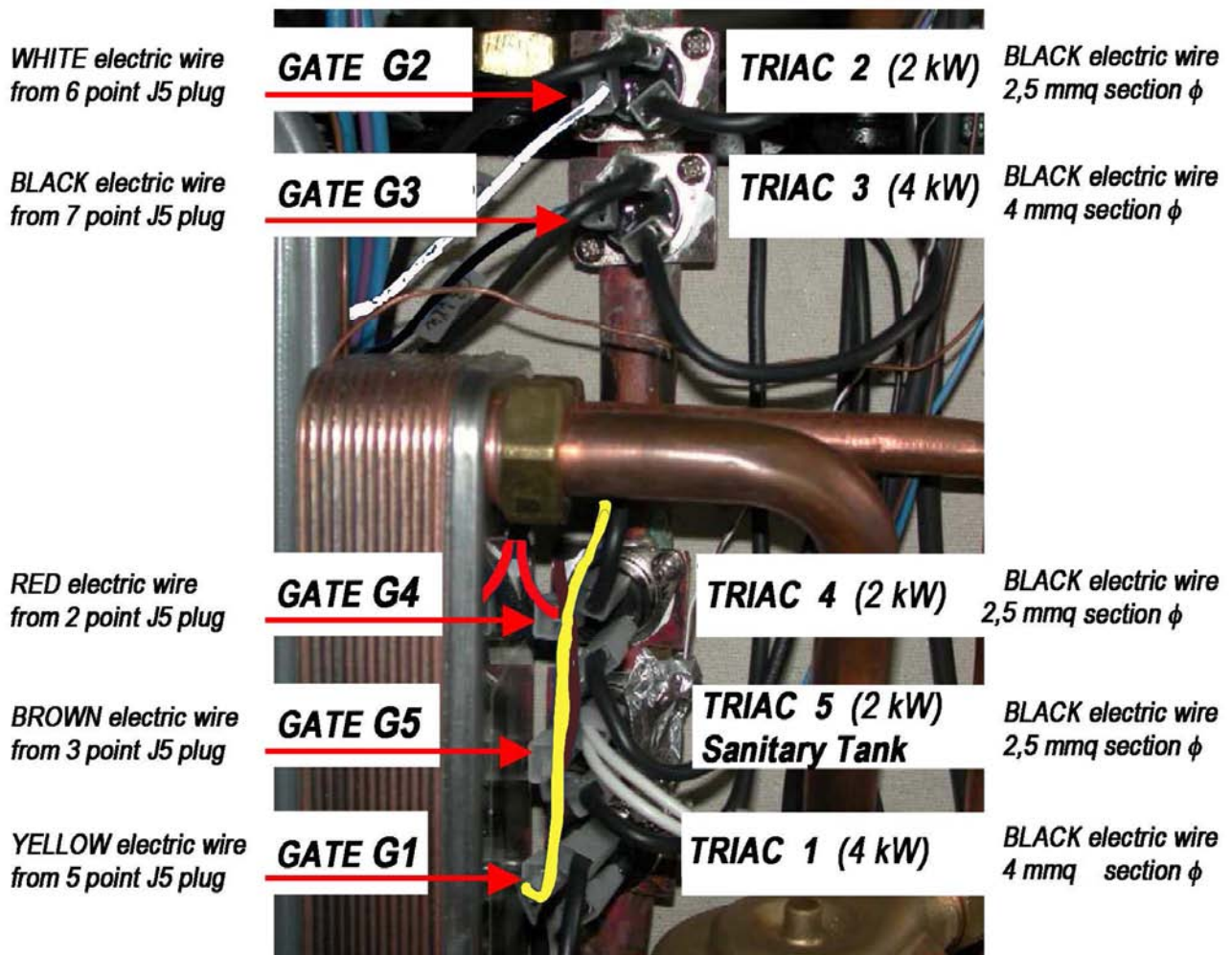
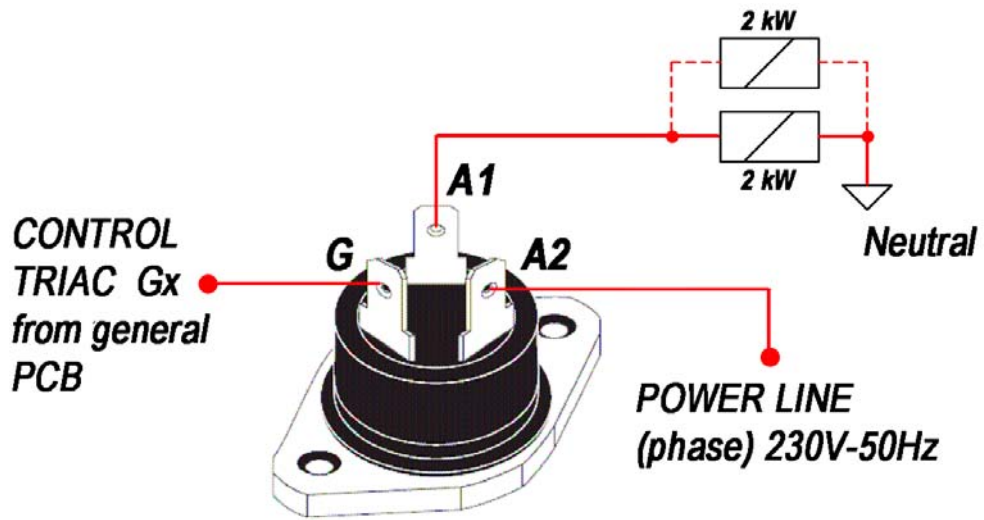



MANUFACTURE CONSTANTS

FUNCTION	Value
DELTA OFF TANK PROBE	0°C
DELTA ON TANK PROBE	-1°C
INTERVENTION TEMPERATURE ANTI LEGIONELLA	65°C
INTERVENTION INTERVAL ANTI LEGIONELLA	7 Days
MAX TEMPERATURE PRIMARY	80°C
TIME OF PUMP FUNCTIONING IN ANTI-LOCK	10 sec
INTERVENTION TIME ANTI-LOCK PUMP	24H
TEMPERATURE ANTIFREEZE ON (only circulator)	7°C
TEMPERATURE ANTIFREEZE ON (heat exchanger ignition)	4°C
TEMPERATURE ANTIFREEZE OFF	20°C

SETPOINT AND PARAMETERS

FUNCTION	Default	RANGE
HEATING SETPOINT	60°C	30 – 75 °C
FLOOR HEATING SETPOINT	30°C	10 – 40 °C
ROOM SETPOINT (with external probe present)	20°C	10 – 30 °C
TANK SETPOINT	60°C	30 – 65 °C
INSTANTANEOUS DHW SETPOINT	50°C	30 – 60 °C

PARAMETERS

FUNCTION	N°	def.	RANGE
EXTERNAL PROBE START UP	1	0	0 – 1
BUILDING COEFFICIENT OF DISPERSION	2	35	5 – 35 °C
SANITARY POST CIRCULATION	3	15	1 – 180 sec
HEATING POST CIRCULATION	4	30	1 – 180 sec
HEATING EXCHANGER CIRCULATION STARTING	5	0	0 – 240 sec
MIN. IGNITION TEMPERATURE CIRCULATOR	6	30	0 – 50 °C
DELIVERY DIFFERENTIAL OF SANITARY	7	15	0 – 20 °C
TYPE KETTLE PRESENT	8	0	0=int. with probe - 1=ext. with thermostat - 2=ext. with probe
TYPE OF SENSOR REQUIRED TANK	9	0	0=flow switch+three-way pneumatic - 1=flow meter +three-way electric
SPEED PUMP PWM OPERATION	10	4	1=400 l/h - 2=800 l/h - 3=1000 l/h - 4=1200 l/h

TEMPERATURES

FUNCTION	N°
DELIVERY TEMPERATURE	t: "Ch"
TANK TEMPERATURE	t: "Dh"
EXTERNAL TEMPERATURE	t: "Ep"
OFFSET SETPOINT OF EXTERNAL PROBE	t: "Se"

SELECTION JUMPERS enable

Jumper	0 / 1
JP7	High temperature / Low temperature plant
JP8	Combined / Heating only
JP9	Sanitary with tank / Sanitary instantaneous



CONTROL OF MAIN HEAT EXCHANGER

According to the required power during the heat request, the controls G1-G4 related to the main exchanger are turned on all or partially.

The actuation of each control is reduced to a lapse of 4 seconds. Higher is the required power, more the control will remain operative in this lapse.

The power in heating or during a sanitary request is calculated by PID algorithm.

Please see in the pictures below two examples related to 40% and 60% of total power.

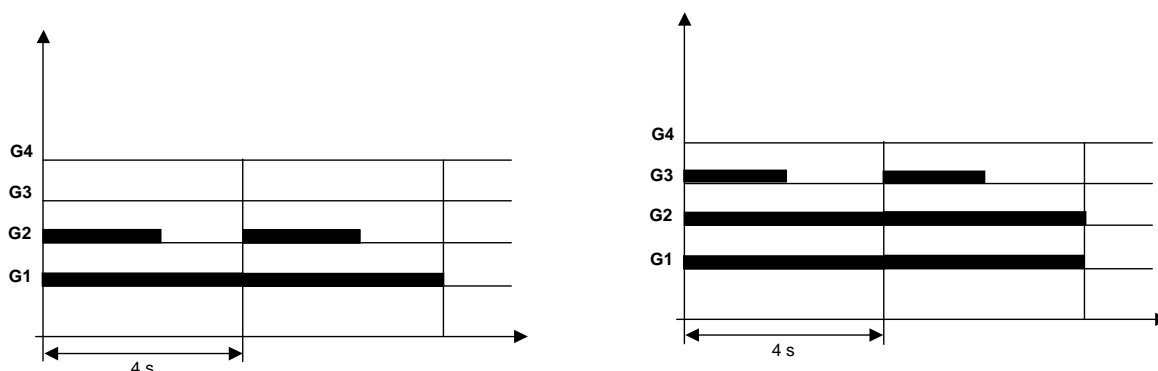

In case of simultaneous request of heating and tank, the controls G1-G4 related to the main heat exchanger will be directed in the following way:

Boiler status	Primary G1-G4	Tank G5
Only heating request	G1 – G4 = modulation	G5 = OFF
Heating request + Tank request	G1–G3 = modulation G4 = OFF	G5 = ON
Heating request + Flow switch request	G1–G3 = modulation G4 = OFF	G5 = ON

Controls rotation:

Every hour the order of ignition of triac G1-G4 controls is rotated in such a way to partition evenly in time the use of all heating elements.



CONTROL OF EXTERNAL PROBE

Installation and functioning at sliding temperature

For the connection of the external probe, it shall be used the Original Kit FIAMMA code F.532 provided in the accessories of the electric boilers Elektra.

The electrical connection shall be done in the external terminal at the general electric panel already prearranged in the standard cabling of the boiler. The connection must be carried out with junction cables and wires having a minimum section of 1,5 mm and, if possible, avoiding the insertion along with electric lines, digital lines of inverter or other not compatible.

After the connection the external probe must be enabled by means of the introduction of a variation of **N°1** parameter, changed from 0 to 1.

Then the setpoint chased by the heating delivery probe will be calculated as follows:



$$T_i = [(T_{room} - T_e) * K_e / 10] + T_{room}$$

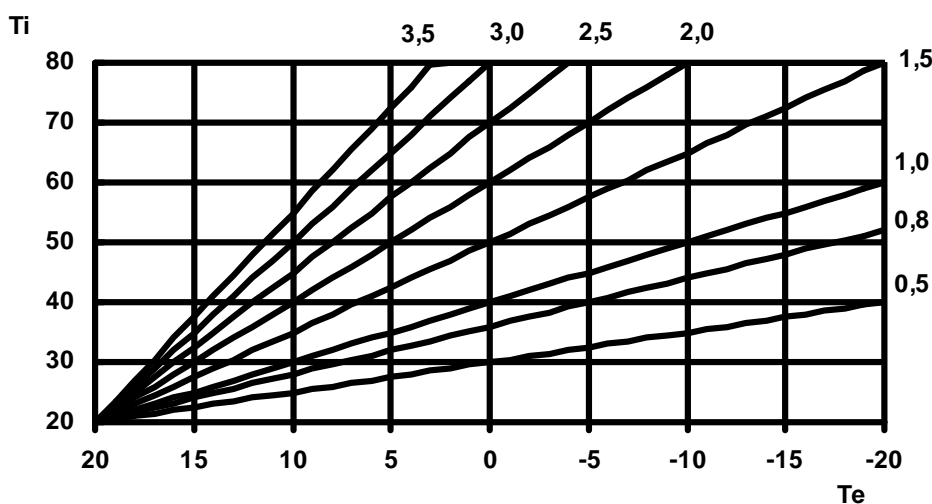

Example of calculation for several values of Ke

The coefficient **Ke** is the leakage of the building and it can be set by **N°2** parameter.

Te, is the temperature measured by the external probe.

Troom is the setpoint related to the desired room temperature.



ANTIFREEZE FUNCTION

In case the delivery probe measures a temperature lower than 7°C, the circulator is activated.

If the temperature goes down the value of 4°C the main heat exchanger is ignited until the delivery temperature has reached 20°C. The antifreeze function is active also with the boiler turned OFF (function in standby mode but with bright switch on).

TANK REQUEST (Jumper JP9 = 0)

Standby or with simultaneous heating request: in this case if the temperature measured by the tank probe is lower than the tank setpoint - 1°C, is activated the control **G5** related to the tank resistance.

When the temperature measured by the probe tank is higher than the tank setpoint, the control **G5** is disconnected.

Sanitary flow switch request: when a request gets by the sanitary flow switch, the control **G5** related to the tank resistance is activated independently by the temperature.

In ECO Mode is not activated any resistance of the primary heat exchanger.

In the COMFORT mode simultaneously are also checked the controls **G1, G2, G3, G4** relative to the primary heat exchanger bringing the flow temperature to the setpoint value tank plus a differential set with parameter **N°7**.

At the end of the request the pump is fueled for a time equal to the value set by parameter **N°3**.

Pre-heat exchanger primary: when COMFORT is activated in standby condition the primary heat exchanger temperature is maintained in order to ensure a prompt response of the sanitary sector. The primary heat exchanger is maintained at a temperature equal to the Setpoint plus a tank temperature difference can be set by parameter **N°7**.

ANTILEGIONELLA FUNCTION

The system checks continuously the tank temperature.

If within a certain time lapse the temperature does not reach 65°C, the tank resistance is automatically ignited in order to avoid bacterium growth.

The time of intervention of legionella function is 3 hours by the first ignition and then every 7 days.

DHW DEMAND INSTANTANEOUS

When receiving a request by the microswitch sanitary, the circulator is powered and controlled commands are **G1, G2, G3, G4** relative to the primary heat exchanger leading the delivery temperature to the setpoint value sanitary + a differential be set with parameter **N°7**.

At the end of the request the pump remains powered for a time equal to the value set by parameter **N°3**.

DEGASSING FUNCTION

The degassing function is activated by simultaneously pressing the keys **J4** and **J7**.

During this function are altered states of operation to maximum and minimum speed of the circulating pump PWM in order to facilitate the escape of air bubbles from the hydraulic circuit.

The sequence is illustrated below.

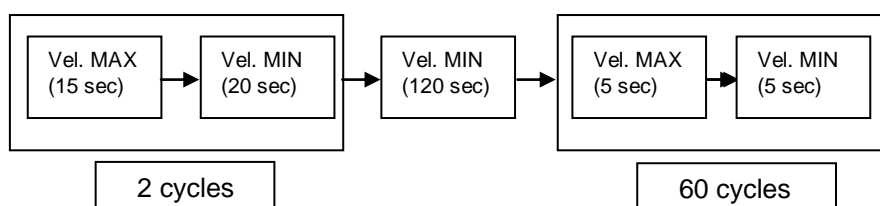

When this function is on the display shows a timer indicating the time at the end of the function.

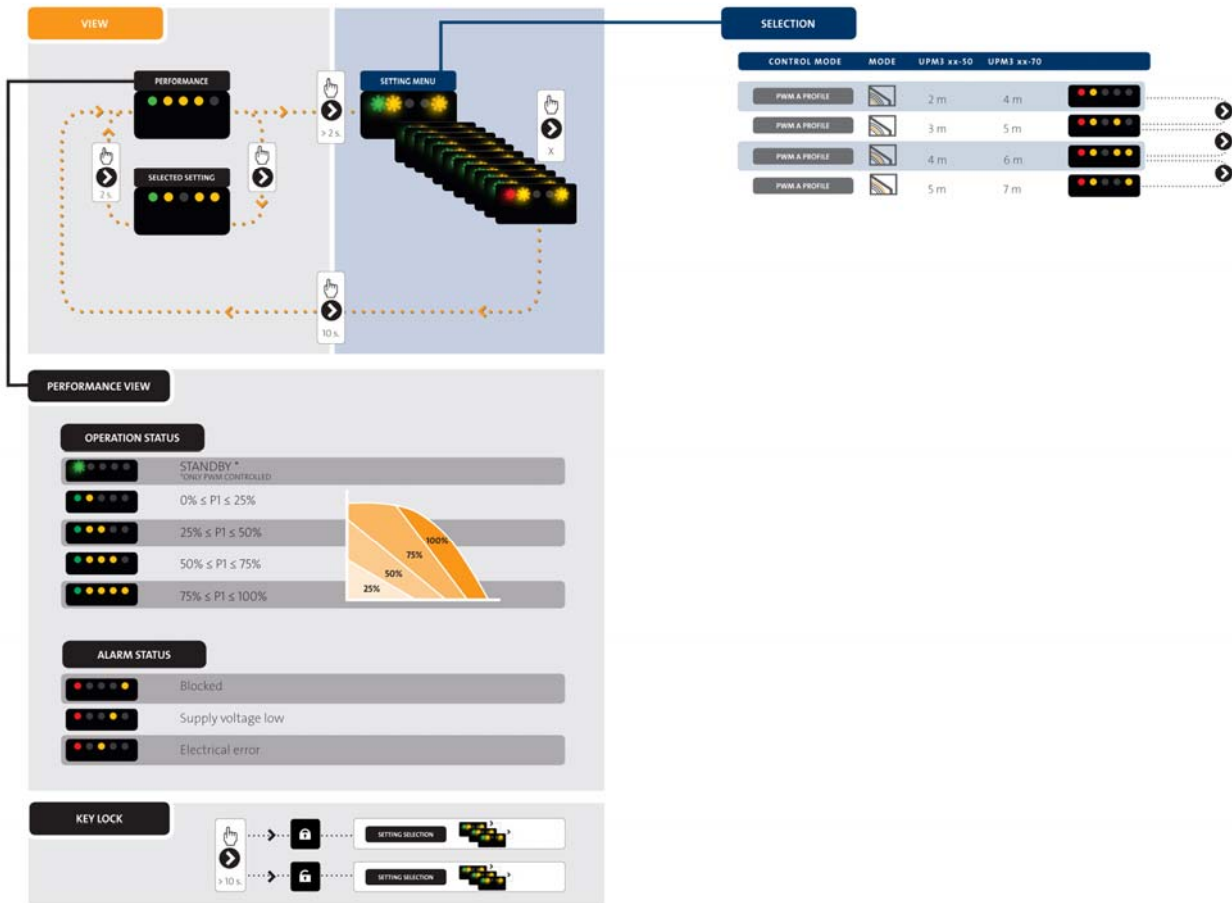

HEATING REQUEST

As the contact of room thermostat closes, if the mainboard is in winter mode, the system pump is only activated if the temperature of the primary heat exchanger is higher than the temperature set by parameter N°6. If the value of temperature measured by the primary heat exchanger probe is lower than the programmed delivery setpoint, the triac are ignited in sequence as for required power. This occurs only after a settable time by parameter N°5. The instant power of the boiler and the related control of triac G1-G4 takes place by means of PID regulator. At the end of the request the pump remains supplied for a time equal to the value programmed by N°4 parameter.

MEANING OF THE KEYS OF TEMPERATURE MENU

To log in temperature menu, press simultaneously J3 and J5 keys. The symbol will appear on the display.

KEY	FUNCTION
J7	Exit by temperature menu
J2	Temperature index increase
J3	Temperature index decrease

MEANING OF KEYS OF PARAMETERS MENU

To log in parameters menu, press simultaneously the keys J2 and J6 for 4 seconds. The symbol will appear on the display.

KEY	FUNCTION
J5	Parameter value decrease
J6	Parameter value increase
J7	Exit by parameters menu
J2	Parameter index increase
J3	Parameter index decrease



“Heating elements status”

The dashes located in the upper part indicate the heating elements status. Each dash corresponds to a 2 kW element. The first 6 dashes refer to heating modules of primary heat exchanger. The dash on the right upper corner refers to the heating module dedicated to the tank (only if JP8=0 and JP9=0)..

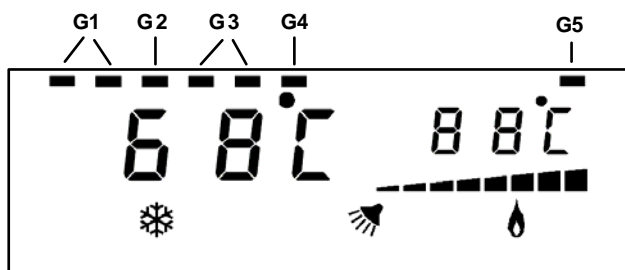

“Heating request”

When an heating request occurs, the temperature measured by the delivery probe is displayed and the symbol III starts to flash. On the small digit is displayed the tank temperature. The instantaneous power of the boiler is indicated by the level of modulation.

In any moment it is possible to observe which triac are turned on.

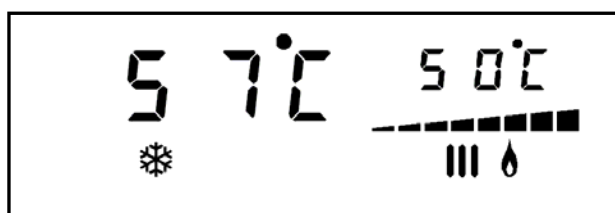

In the case of boiler with heating only (JP8 = 1) is only displayed the temperature of the primary heat exchanger:

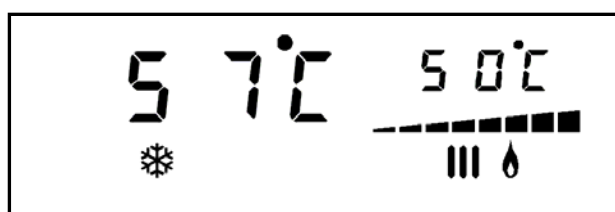

“Flow switch request (comfort function)” (only if JP8=0)

When a flow switch request occurs, the temperature measured by the delivery probe is displayed and the symbol \square starts to flash. On the small digit is displayed the tank temperature. The instantaneous power of the boiler is indicated by the level of modulation.

In any moment it is possible to observe which triac are turned on.

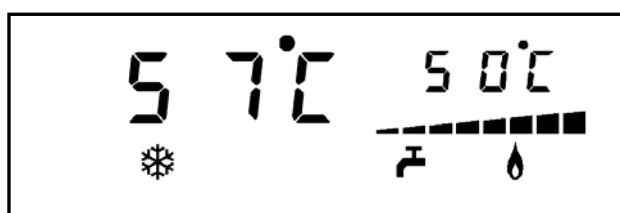



“Temperature display”

On the small digit will appear the writing **t** : followed by the description of the selected temperature, while the big digit will show the temperature value.

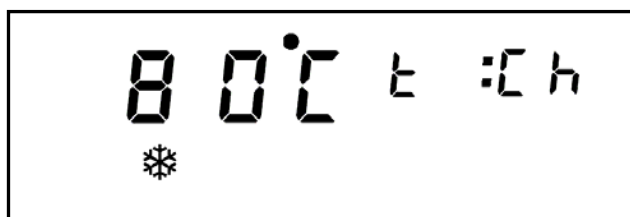

FUNCTION	N°
DELIVERY TEMPERATURE	t: “Ch”
TANK TEMPERATURE	t: “Dh”
EXTERNAL TEMPERATURE	t: “Ep”
EXTERNAL PROBE OFFSET SETPOINT	t: “Se”

“Parameters display”

On the small digit will appear the writing **P** : followed by the index of the selected parameter, while the big digit will show the parameter value.

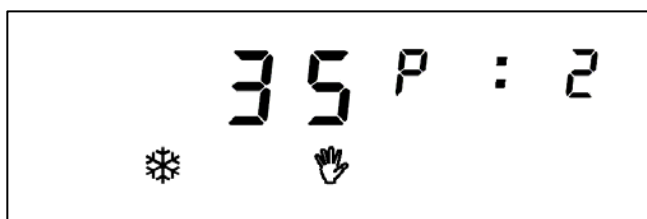

MALFUNCTIONING CODE

When a malfunction occurs, the writing “Err F X” appears, where X indicates the related error code

CODE “Err”	MEANING
9	Hardware eeprom failure
1	Insufficient system water pressure
4	Err tank probe / instant sanitary - only if JP8 = 0
3	Err boiler delivery probe
8	Safety thermostat block

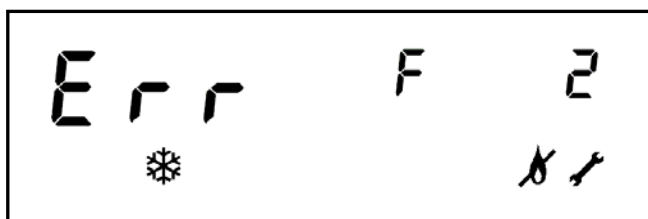

FUNCTIONING WITH REMOTE CONTROL ENCRONO OT1, OT2 or OT11



LOOK OF THE REMOTE CONTROL ENCRONO OT1, OT2 and KRONOS OT11

Elektra ... BP-L, can be connected by means of its card and an additional module to install on a prearranged part, to a compatible remote control device Opentherm®, like Encrono OT1 or OT2 or OT11. This can be obtained by means of the interface card (additional module).

When the card finds the connection with the remote control, on the LCD display appears the symbol .

The compatible remote control OpenTherm becomes the master of the entire system, therefore almost

all the functionalities, as the setting of heating and hot sanitary water setpoint or the control of system status, are directly executable by it, in relation with the kind of application on which the card is used.

By means of the remote control it is possible to restore the system from the non-volatile lock status.

The communication between the remote control and the electronic card fitted with D.E.S. system can be interrupted in the following ways:

- Interruption of the connection between remote control and card:

In this case, after 1 minute, the card starts to work in local mode.

- Noise on communication cable between remote control and card:

In this case it is possible that remote control and card do not manage to communicate (wrong data interpretation), therefore, after a certain lapse appears the related error signal. If the noise on the communication cable ends, the dialog between remote control and the card is automatically restored and the malfunction disappears.

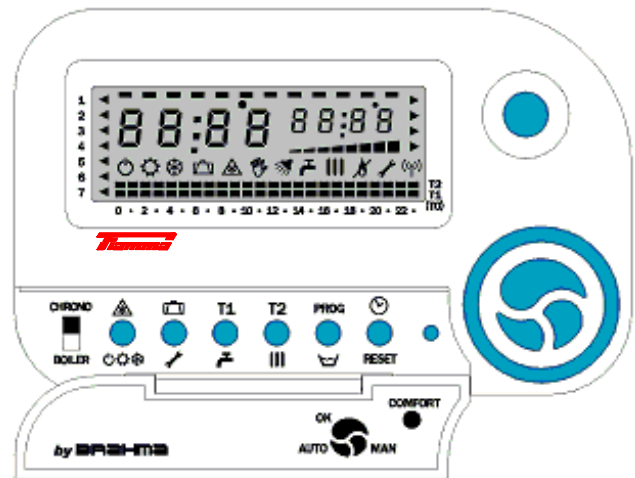

TRANSPARENT PARAMETERS

This function is available only with the use of remote control OT2 or OT11. The digital electronic PCB is equipped with 5 parameters adjustable by the installer, in order to set the functioning of the system in conformity to the final application. The parameters have the same meaning of the ones described in the table “parameters”.



Parameters Table

FUNCTION	N°	def.	RANGE
EXTERNAL PROBE ENABLING	1	0	0 – 1
BUILDING LEAKAGE COEFFICIENT	2	35	5 – 35 °C
SANITARY POST CIRCULATION	3	15	1 – 180 sec
HEATING POST CIRCULATION	4	30	1 – 180 sec
HEATING EXCHANGER CIRCUL. START	5	0	0 – 240 sec
MIN. IGNITION TEMPER. CIRCULATOR	6	30	0 – 50 °C
DELIVERY DIFFERENTIAL OF SANITARY	7	15	0 – 20 °C

RANGE OF SETPOINT ADJUSTABLE BY MEANS OF REMOTE CONTROL

Interval of temperature setting with high temperature system (JP7 = 0)	30 °C ÷ 75 °C - step 1°C Pre-set value: 60 °C
Interval of temperature setting with low temperature system (JP7 = 1)	15 °C ÷ 40 °C - step 1°C Pre-set value: 30 °C
Interval of tank temperature setting	30 °C ÷ 65°C - step 1°C Pre-set value: 60 °C

FUNCTIONING OF BOILER ELEKTRA WITH REMOTE CONTROL

The actuation of heating mode takes place after an heating request from remote control (value of heating setpoint calculated by remote control higher than heating setpoint set by the user on remote control divided by two) and in the winter mode status.

It also enabled the relay which controls the valve opening area managed by Enchrone/Kronos.

HOT SANITARY WATER MODE (if only JP8 = 0)

The electric card of Elektra operates in the same way described previously. The desired setpoint is set by the user on the remote control.

Through the Enchrone OT1/OT2 you can enable the ECO/COMFORT by pressing . When the ECO function is active, the temperature of sanitary and the symbol is the alternating temperature. In the COMFORT mode, the temperature of the hot water circuit appears fixed only when there is a request by the micro sanitary.

CONTROL PANEL IN USER MODE

The pressure of one key/two keys activates the backlighting of LCD display.

KEY	FUNCTION
J5	Disabled in Opentherm mode
J6	Disabled in Opentherm mode
J7	Unlock error of safety thermostat
J4	Disabled in Opentherm mode
J2	Disabled in Opentherm mode
J3	Disabled in Opentherm mode
J5 + J6	Enabling of Eco/Comfort function



CONTROL PANEL IN INSTALLER MODE

The keys have the same functioning described on par. "Control panel in user mode".

DISPLAY OF MALFUNCTIONS

CODE "Err"	MEANING
F 009	<i>Hardware eeprom fault</i>
F 001	<i>Insufficient water pressure in the system</i>
F 004	<i>Tank probe error / instant sanitary - only if JP8 = 0</i>
F 003	<i>Boiler delivery probe error</i>
F 008	<i>Safety thermostat lock</i>

For further details related to remote controls series OT1 / OT2 / OT11, please see the related technical specifications.

SPARE PARTS

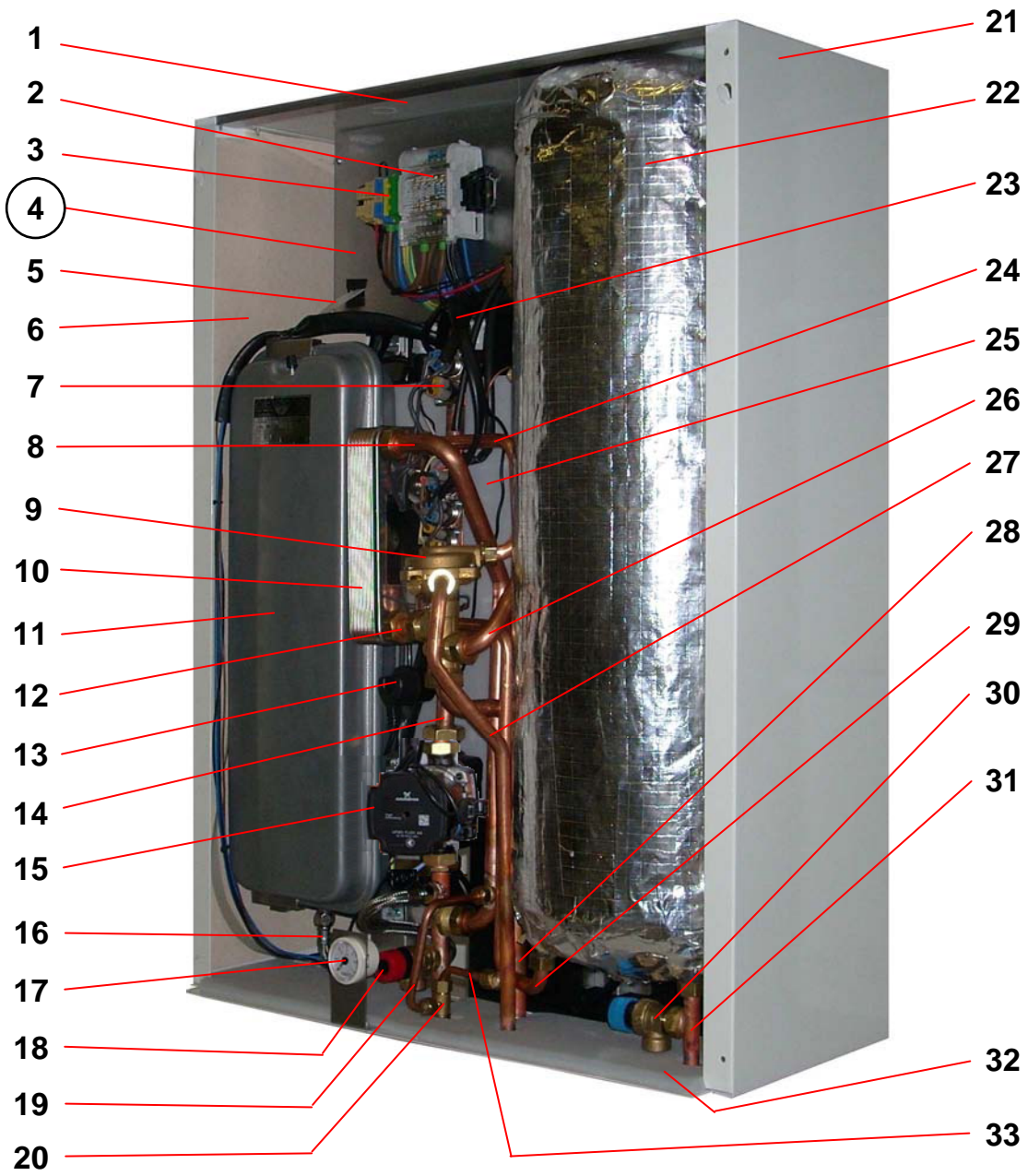

4 Particular

Particular : Boiler body / resistances

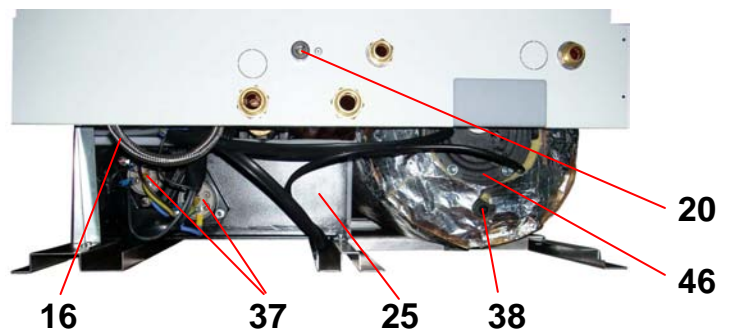
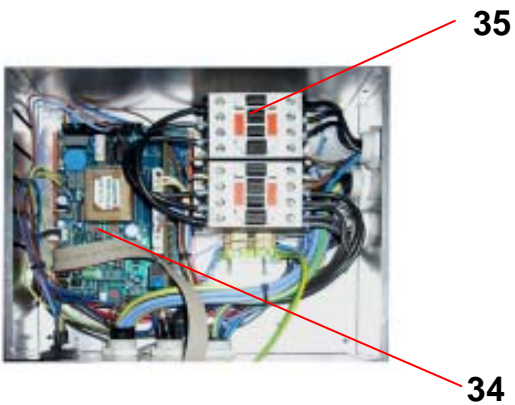

Upper particular / resistance

Front unit

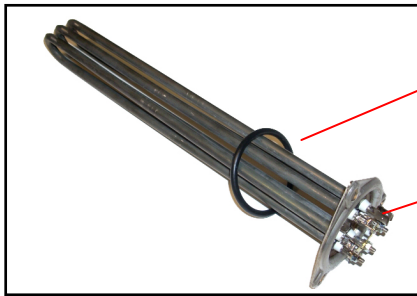

36

37

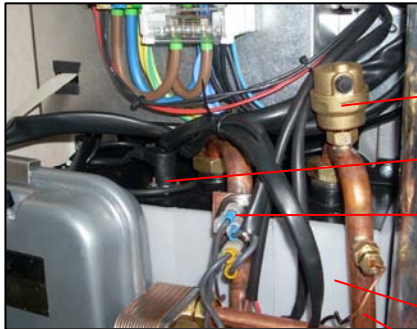

40

39

7

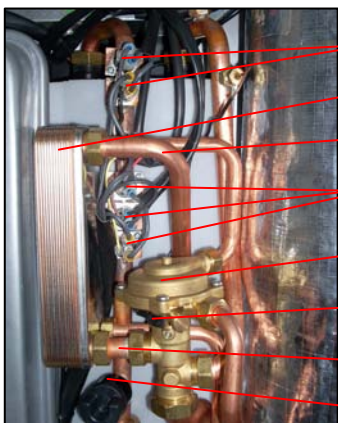

7

10

8

7

9

45

12

13

41

25

26

42

43

44

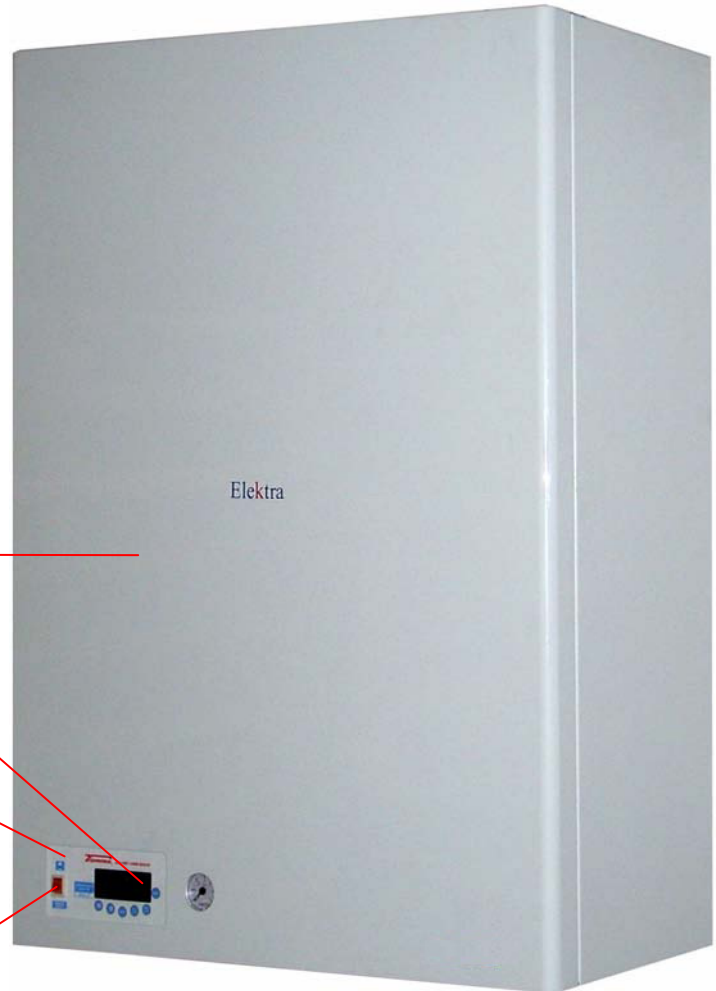

Particular : Flange/probe/resistance/anode group Sanitary tank.

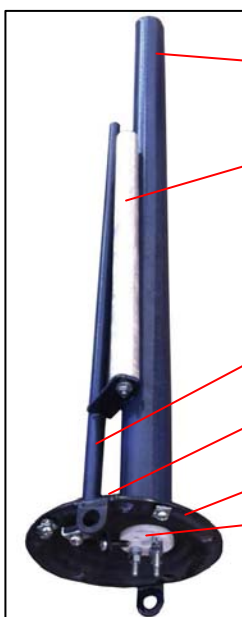

46

47

46

48

46

49

*The flange/tank group, included in one vitrified piece, sheath probe, resistance probe, and inspection and support flange.
The substitution of the anode magnesium, involves the disassembly of the group.
The substitution of the electrical resistance does not involve the emptying of the sanitary tank because inside the vitrified steel probe.*

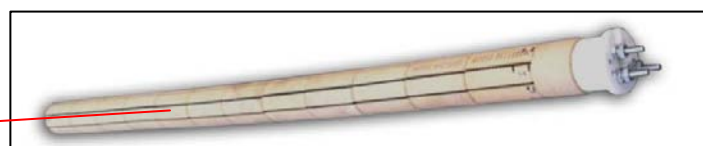

Spare parts - Legend



1	Upper closing fairing of Elektra .. B/BP-L.	Cod.P.2025
2	Tetrapolar Terminal block for Elektra 6/12/18 ...	Cod.P.2054
	Tetrapolar Terminal block for Elektra 24 ...	
3	Terminal of the electric supply line 230V (Ph).	Cod.P.2073
	Terminal of the electric supply line 230V (blue - N).	Cod.P.2072
	Terminal line of electrical ground (green/yellow).....	Cod.P.2074
4	General electric box (panel circuit board / contactor).	
5	Flat cable connection LCD display.	Cod.P.2095
6	Left side panel of casing.	Cod.P.2030
7	Triac of electric power (40A-600V).	Cod.P.2293
8	Return tube heat exchanger-pump.	Cod.P.2044
9	5 way diverter valve.	Cod.P.916
10	Plate heat exchanger for Elektra C/BP 6 kW version.	Cod.P.9098
	Plate heat exchanger for Elektra C/BP 12 kW version..	Cod.P.9098
	Plate heat exchanger for Elektra C/BP 18 kW version..	Cod.P.7311
	Plate heat exchanger for Elektra C/BP 24 kW version..	Cod.P.7313
11	Expansion vessel 8 lt. C/BP 6 kW version.	Cod.P.289
	Expansion vessel 10 lt. C/BP 12/18/24 kW version.	Cod.P.1846
12	Diverter valve-heat exchanger tube.	Cod.P.2041
13	Water pressure switch (minimum pressure).	Cod.P.1082
14	Return pump-boiler body tube.	Cod.P.2037
15	Circulator at variable prevalence (electronic pump).	Cod.P.7326
16	Flexible tube for expansion vessel.	Cod.P.1531
17	Hydrometer.	Cod.P.141
18	Heating Safety valve - 3 bar..	Cod.P.158
19	Flow regulator valve	Cod.P.7440
20	Filling tap water ¼"-¼".	Cod.P.6605
21	Right side panel of casing.	Cod.P.2029
22	Sanitary tank for Elektra .. B/BP..	Cod.P.1999
23	Elektra .. BP-L. electrical wiring.	Cod.P.7500
24	Outlet tube heat exchanger- diverter valve.	Cod.P.2045
25	Body boiler Elektra 6 N/C/B/BP-L.	Cod.F.1955
	Body boiler Elektra 12 N/C/B/BP-L.	Cod.F.1955
	Body boiler Elektra 18 N/C/B/BP-L.	Cod.F.1956
	Body boiler Elektra 24 N/C/B/BP-L.	Cod.F.1957
26	Outlet heating tube diverter valve-body boiler.	Cod.P.2039
27	Inlet tube cold water-diverter valve.	Cod.P.2046
28	Template connection pipes	Cod.P.2023
29	Inlet tube tank water (outlet exchanger-tank).....	Cod.P.2038
30	Sanitary safety valve 6,5 bar.	Cod.P.7540
31	Outlet tube hot water tank (tank-dima).	Cod.P.2036
32	Lower panel (lower grid).	Cod.P.2024
33	Inlet tube filling tap.	Cod.P.1826
34	PCB of operating (Elektra N/C/B/BP..).	Cod.P.2057
35	Contactator of power for Elektra 6 ...	Cod.P.2103
	Contactator of power for Elektra 12 ...	Cod.P.2067
	Contactator of power for Elektra 18 ..	Cod.P.2104
	Contactator of power for Elektra Elektra 24 ...	Cod.P.2101
36	O-Ring gasket for 3x2 kW electrical resistance for Elektra 6÷24.	Cod.P.2078
37	Electrical resistance. 3x2 kW for Elektra 6÷24 ...	Cod.P.2718



38	<i>Drain tap ¼" for Elektra .. boiler/tank.</i>	<i>Cod.P.2190</i>
39	<i>Contact safety thermostat 100°C. Elektra .. .</i>	<i>Cod.P.1195</i>
40	<i>Automatic bleed valve (Jolly).</i>	<i>Cod.P.174</i>
41	<i>Front panel Elektra .. B/BP-L</i>	<i>Cod.P.2031</i>
42	<i>Display Lcd (Lcd pcb).</i>	<i>Cod.P.1763</i>
43	<i>Instrument panel of Elektra (profil+lexan keyboard P.2099).</i>	<i>Cod.P.2164</i>
44	<i>Lighting general switch (On-Off switch).</i>	<i>Cod.P.1099</i>
45	<i>Sanitary microswitch.</i>	<i>Cod.P.561</i>
46	<i>Flange/sheath probe support/sheath group for sanitary resistance.</i>	<i>Cod.P.2163</i>
47	<i>Magnesium anode Elektra .. B/BP-L.</i>	<i>Cod.P.2165</i>
48	<i>Gasket flange Elektra .. B/BL.. tank.</i>	<i>Cod.P.2166</i>
49	<i>Ceramic electric resistance 2 kW for sanitary tank.</i>	<i>Cod.P.2167</i>

official distributor for the United Kingdom (GB)



ABCOT UK Ltd.

Green Acres – Oakley Green Road – WINDSOR BERKSHIRE SL4 4QF.

Tel. 01628.636099 – 01628.676900 – Fax. 01628.676958 - E-mail : euoboilerparts@hotmail.co.uk

www.euoboilerparts.co.uk



www.electricboilerscompany.com 0208 9982024



FIAMMA GIRO s.r.l. Company group



Sede legale e stabilimento : via L. Landucci n°2/B - 51100 PISTOIA - ITALY

Tel.(+39).0573.532812 Fax.(+39).0573.532890 - E.mail : fiammaPT@fiammagiro.it

Filiale e stabilimento : via P. Bettini n°19 - 37049 VILLA BARTOLOMEA (VR) - ITALY

Tel.(+39).0442.659028 Fax.(+39).0442.659045 - E-mail : fiammaVR@fiammagiro.it

www.fiammagiro.com